

# Z-Wave In-wall Switch

09.ZV09SAPS.04739



**Important:** Read All Instructions Prior to Installation

## Function introduction

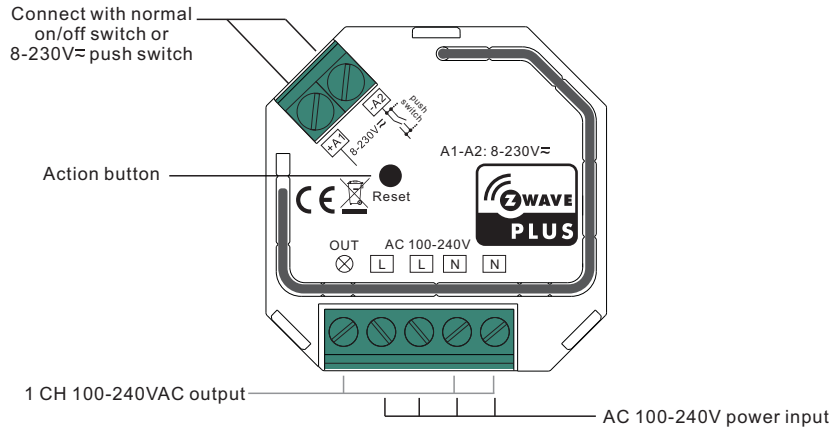

## Product Data

Z-Wave Frequency	868.42 MHz (EU)/869.0 MHz (RU)/908.42 MHz (US)/921.42 MHz (ANZ)
Input Voltage	AC100-240V
Output Voltage	AC100-240V
Output Current	1.8A max.
Operating temperature	0 to 40°C
Relative humidity	8% to 80%
Dimensions	45.5x45x20.3mm

Compatible Load Types			
Load Symbol	Load Type	Maximum Load	Remarks
	LED lamps with transformers	200W @ 220V 100W @ 110V	Due to variety of LED lamp designs, maximum number of LED lamps is further dependent on power factor result when connected to switch.
	LED drivers	200W @ 220V 100W @ 110V	Maximum permitted number of drivers is 200W divided by driver nameplate power rating.
	Incandescent lighting, HV Halogen lamps	400W @ 220V 200W @ 110V	
	Low voltage halogen lighting with electronic transformers	200W @ 220V 100W @ 110V	

## Safety & Warnings

- DO NOT install with power applied to device.
- DO NOT expose the device to moisture.

## Quick Start

How to install:

- Step 1: power on the Z-Wave in-wall switch.
- Step 2: activate inclusion mode on your Z-Wave controller.
- Step 3: activate inclusion mode of the switch by triple press the action button on the switch. The switch will be included to Z-Wave network.

## Product Description

The in-wall switch is a Z-Wave device that is used to switch ON/OFF the connected light and can be controlled by other Z-Wave devices. The In-wall switch can be included and operated in any Z-Wave network with other Z-Wave certified devices from other manufacturers and/or other applications. All non-battery operated nodes within the network will act as repeaters regardless of vendor to increase reliability of the network.

The encryption mode that the switch supports is S2 Unauthenticated. When the switch is being included into a Z-Wave network, you can use your primary controller/gateway to enable encryption mode or disable encryption. (The primary controller/gateway shall support encryption mode configuration). The switch supports OTA and can update firmware wirelessly.

## Operation

### Installation Guide

Please read carefully the enclosed user manual before installation of the in-wall switch, in order to ensure an error-free functioning.

**ATTENTION:** Prior to the assembly of the product, the voltage network has to be switched OFF and ensured against re-switching.

### Inclusion (adding to a Z-Wave network)

1. Set primary controller/gateway into inclusion mode (Please refer to your primary controllers manual on how to turn your controller into inclusion).
2. Power on the in-wall switch and set it into inclusion mode. There are two methods to set the in-wall switch into inclusion mode:
  - 1)Repower on the switch, it will be set into inclusion mode automatically, and waiting to be included.
  - 2)Triple press the action button on the switch, it will set the switch into inclusion mode.

### Exclusion (removing from a Z-Wave network)

There are two exclusion methods:

Method 1: Exclusion from the primary controller/gateway as follows:

1. Set the primary controller/gateway into exclusion mode (Please refer to your primary controllers manual on how to set your controller into exclusion).
2. Triple press the action button, the switch will be set to exclusion mode, and waiting to be excluded, then the switch will be excluded from the network.

Method 2: Factory reset the switch will force the switch to be excluded from a network. (please refer to the part "Factory Reset" of this manual)

Note: Factory reset is not recommended for exclusion, please use this procedure only if the primary controller/gateway is missing or otherwise inoperable.

### Factory Reset

Press and hold down the action button for over 10 seconds, the switch will be reset to factory defaults.

### Association

Z-Wave devices control other Z-Wave devices. The relationship between one device controlling another device is called association. In order to control a different device, the controlling device needs to maintain a list of devices that will receive controlling commands. These lists are called association groups and they are always related to certain events (e.g. button pressed). In case the event happens all devices stored in the respective association group will receive a common wireless command.

### Association Groups:

Association Groups	Group Name	Max Nodes	Description
Group 1	Lifeline	5	<p>1. When press and hold down "Reset" button to factory reset the dimmer, send "Device Reset Locally Notification CC" to associated devices of this group.</p> <p>2. When load state changes, send "Basic Report CC" to associated devices of this group.</p> <p>3. When over temperature protection is detected, send "Emergency shutoff status" to Lifeline.</p>

### Set and unset associations:

(Note: All association information will be cleared automatically once the switch is excluded from a network.)

Set association by operating primary controller/gateway to send packets to the switch:

The primary controller/gateway sends packets to the switch using "Command Class ASSOCIATION"

### Operating the device

Short press the action button on the switch to switch ON/OFF the load.

### Node Information Frame

The Node Information Frame is the business card of a Z-Wave device. It contains information about the device type and the technical capabilities. The inclusion and exclusion of the device is confirmed by sending out a Node Information Frame. Beside this it may be needed for certain network operations to send out a Node Information Frame.

How to send out Node Information Frame:

When the switch is set to inclusion/exclusion mode again, it will send out Node Information Frame, there are 2 kinds of operation as follows:

- triple press the action button, the dimmer will be set to inclusion/exclusion mode, then send out Node Information Frame.
- When the switch is under inclusion mode, there are two kinds of operation:
  - Triple press inclusion/exclusion button, the switch will be set to inclusion mode again, and send out Node Information Frame.
  - Power off and power on the switch, it will be set to inclusion mode automatically, and send out Node Information Frame.

### Technical Data

Wireless Range	up to 100 m outside, on average up to 40 m inside buildings
SDK	6.71.03
Explorer Frame Support	Yes
Device Type	On/Off Power Switch
Generic Device Class	GENERIC_TYPE_SWITCH_BINARY
Specific Device Class	SPECIFIC_TYPE_POWER_SWITCH_BINARY
Role Type	Always On Slave (AOS)
Routing	Yes

### SUPPORTED COMMAND CLASS

Node Info		Security Command Supported Report	
COMMAND_CLASS_ZWAVEPLUS_INFO	V2	COMMAND_CLASS_MANUFACTURER_SPECIFIC	V2
COMMAND_CLASS_TRANSPORT_SERVICE	V2	COMMAND_CLASS_VERSION	V2
COMMAND_CLASS_SECURITY	V1	COMMAND_CLASS_SWITCH_BINARY	V1

COMMAND_CLASS_SECURITY_2	V1	COMMAND_CLASS_SCENE_ACTIVATION	V1
COMMAND_CLASS_SUPERVISION	V1	COMMAND_CLASS_SCENE_ACTUATOR_CONF	V1
		COMMAND_CLASS_NOTIFICATION	V8
		COMMAND_CLASS_CONFIGURATION	V1
		COMMAND_CLASS_ASSOCIATION_GRP_INFO	V3
		COMMAND_CLASS_ASSOCIATION	V2
		COMMAND_CLASS_FIRMWARE_UPDATE_MD	V4
		COMMAND_CLASS_POWERLEVEL	V1
		COMMAND_CLASS_DEVICE_RESET_LOCALLY	V1

### Notification Command Class

The switch supports Emergency shutoff, when over temperature (95°C) protection is detected by the built-in thermistance, the dimmer will send out Emergency shutoff status to Lifeline.

Notification Type	Notification
System (0x09)	Emergency shutoff status (0x07)

### Configuration Command Class

Parameter	Size	Description	Default Value
2	1	<p>Info: Saving load state before power failure</p> <p>0 – shutoff load</p> <p>1 – turn on load</p> <p>2 – save load state before power failure</p>	2
3	1	<p>Info: Enable/disable to send the basic report to the Lifeline when the load state changed</p> <p>(When value set as 1, re-power on the switch, it will send Basic report automatically)</p> <p>0 – Disable to send Basic report</p> <p>1 – Enable to send Basic report</p>	1
5	1	<p>External switch type</p> <p>0 – Push button switch</p> <p>1 – normal on/off switch</p>	1
7	1	<p>Enable/disable the switch to be added to or removed from a network through external switch (when enables this function, triple press the external switch within 1.5 seconds to enable the switch to be added or removed)</p> <p>0 - disable</p> <p>1 - enable</p>	1

## Wiring Diagram

### Notes for the diagrams:

L - terminal for live lead

N - terminal for neutral lead

Out - output terminal of the device (controlling connected light source)

+A1 - terminal for switch

-A2 - terminal for grounding to the switch connected to the device

### (1) With Normal On/Off Switch

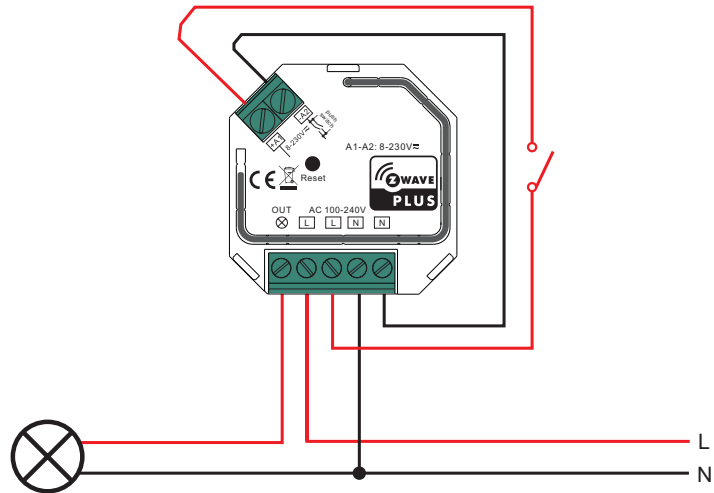

### (2) With Single Push Button Switch

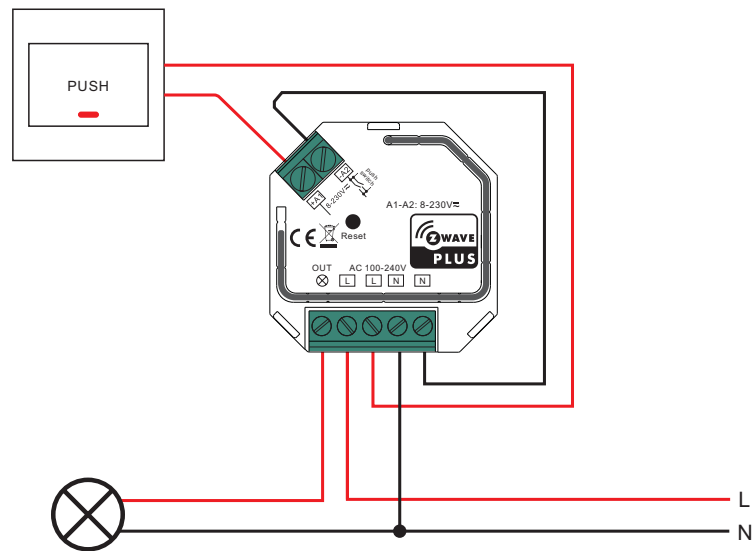

### 3) With Multiple Push Switches for Multiple Control Points

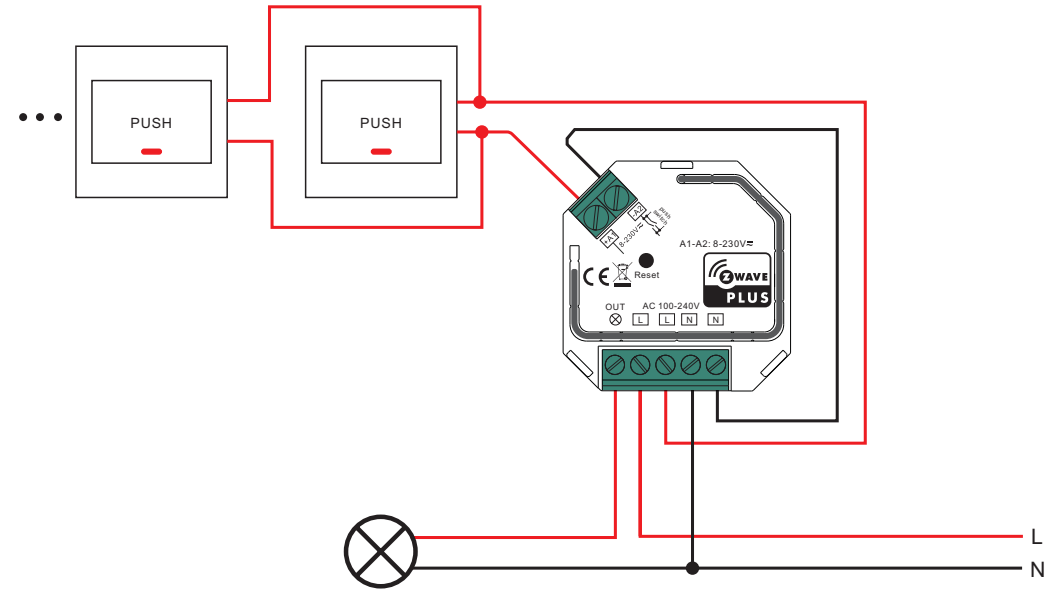

### Product Dimension

