

BRUKSANVISNING
INSTRUCTION MANUAL

LED ARBEIDSLAMPE
10W/30W/50W

220-240V/AC - 50Hz IP65

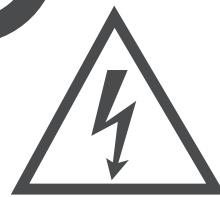

LED reduserer strømkostnadene og er derfor også meget miljøbesparende.

Armaturet er tilpasset Nordiske forhold. Robust og god arbeidslys for mange bruksområder. Herdet frontglass. Enkel innstallering. Strømkobling direkte til 230V stikkontakt. 1,5 m. kabel.

LED reduces energy costs and is therefore also very eco-friendly.

The fixture is adapted to Nordic conditions. Resilient and excellent working light for many uses. Tempered glass cover. Easy installation. Power Connection directly to the 230V outlet. 1,5 m. cable.

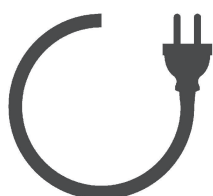

Spenning: 220-240V~50Hz
LED effekt: 10W/30W/50W
Lysstyrke: 800lm/2400lm/4000lm
Tetthetsgrad: IP65
Inkluderer 1.5M kabel med IP44 Schuko plugg.

Operating voltage: 220-240V~50Hz
LED power: 10W/30W/50W
Luminous Efficiency: 800lm/2400lm/4000lm
IP Rating: IP65
Includes 1.5M cable with IP44 schuko.

MÅL / MEASURES

10W

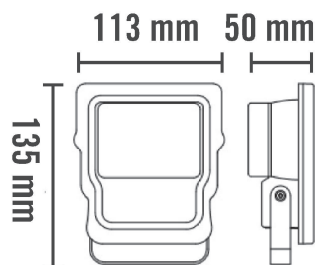

30W

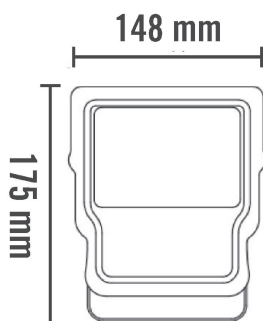

50W

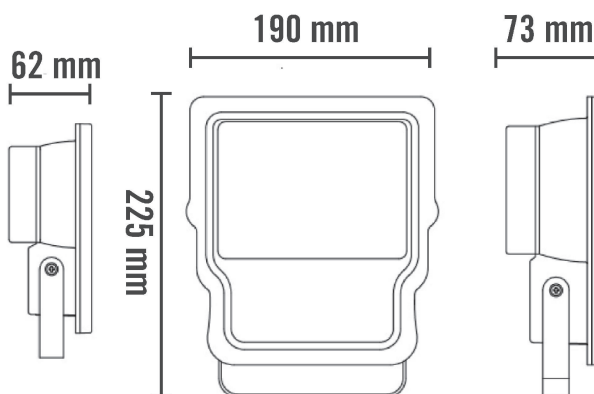

ADVARSEL

1. Produsenten vil ikke holdes ansvarlig for feil installasjon, gal eller upassende bruk og uautorisert forandring av armaturen. Feil som oppstår på grunn av ovennevnte advarsler kan resultere i alvorlige skader.
2. Lyskilden i denne armaturen skal kun erstattes av produsent eller hans serviceagent eller tilsvarende kvalifisert person.

WARNING

1. The manufacturer will not be held responsible for improper installation, incorrect or improper use and unauthorized alteration of the luminaire. Errors that occur because of the above warnings can result in serious injuries.
2. The light source contained in this luminaire shall only be replaced by the manufacturer or his service agent or a similar qualified person.